

ORF307 – Optimization

13. Duality

Ed Forum

\mathbb{C}_B

$$A = \begin{bmatrix} | & | & | & | \\ | & | & | & | \\ | & | & | & | \end{bmatrix} \quad A_B = \begin{bmatrix} | & | \end{bmatrix}$$

- I was still a little confused about the notation for the bases, and was wondering if we could cover this in more detail (i.e. $B = \{1, 2\}$, A_B , etc.)?
- A question I have is about the software, is python the best platform to do optimization problems on? What do large companies use?

Complexity

Complexity of a single simplex iteration

$$\begin{array}{l} \min c^T x \\ \text{st. } Ax = b \\ x \geq 0 \end{array}$$

1. Compute the reduced costs \bar{c}
 - Solve $A_B^T p = c_B$
 - $\bar{c} = c - A^T p$
2. If $\bar{c} \geq 0$, x **optimal. break**
3. Choose j such that $\bar{c}_j < 0$
4. Compute search direction d with $d_j = 1$ and $A_B d_B = -A_j$
5. If $d_B \geq 0$, the problem is **unbounded** and the optimal value is $-\infty$. **break**
6. Compute step length $\theta^* = \min_{\{i \in B | d_i < 0\}} \left(-\frac{x_i}{d_i} \right)$
7. Define y such that $y = x + \theta^* d$
8. Get new basis \bar{B} (i exits and j enters)

Complexity of a single simplex iteration

1. Compute the reduced costs \bar{c}
 - Solve $A_B^T p = c_B$
 - $\bar{c} = c - A^T p$
2. If $\bar{c} \geq 0$, x **optimal. break**
3. Choose j such that $\bar{c}_j < 0$
4. Compute search direction d with $d_j = 1$ and $A_B d_B = -A_j$
5. If $d_B \geq 0$, the problem is **unbounded** and the optimal value is $-\infty$. **break**
6. Compute step length $\theta^* = \min_{\{i \in B \mid d_i < 0\}} \left(-\frac{x_i}{d_i} \right)$
7. Define y such that $y = x + \theta^* d$
8. Get new basis \bar{B} (i exits and j enters)

Bottleneck
Two linear systems

Linear system solutions

Very similar linear systems

$$A_B^T p = c_B$$

$$A_B d_B = -A_j$$

Linear system solutions

Very similar linear systems

$$\begin{aligned} A_B^T p &= c_B \\ A_B d_B &= -A_j \end{aligned}$$



***LU* factorization**
 $(2/3)n^3$ flops

$$A_B = PLU$$

Linear system solutions

Very similar linear systems

$$\begin{aligned} A_B^T p &= c_B \\ A_B d_B &= -A_j \end{aligned}$$



LU factorization
 $(2/3)n^3$ flops

$$A_B = PLU$$



Easy linear systems

$4n^2$ flops

$$\begin{aligned} U^T L^T P^T p &= c_B \\ PLU d_B &= -A_j \end{aligned}$$

Linear system solutions

Very similar linear systems

$$\begin{aligned} A_B^T p &= c_B \\ A_B d_B &= -A_j \end{aligned}$$

LU factorization
 $(2/3)n^3$ flops

$$A_B = PLU$$

Easy linear systems

$4n^2$ flops

$$\begin{aligned} U^T L^T P^T p &= c_B \\ PLU d_B &= -A_j \end{aligned}$$

Factorization is expensive

Do we need to recompute it at every iteration?

Basis update

Index update

- j enters (x_j becomes θ^*)
- $i = B(\ell)$ exists (x_i becomes 0)

Basis update

Index update

- j enters (x_j becomes θ^*)
- $i = B(\ell)$ exists (x_i becomes 0)



Basis matrix change

$$A_{\bar{B}} = A_B + (A_i - A_j)e_{\ell}^T$$

Basis update

Index update

- j enters (x_j becomes θ^*)
- $i = B(\ell)$ exists (x_i becomes 0)



Basis matrix change

$$A_{\bar{B}} = A_B + (A_i - A_j)e_{\ell}^T$$

$$A = \begin{bmatrix} 1 & 2 & 2 & 1 & 0 & 0 \\ 2 & 1 & 2 & 0 & 1 & 0 \\ 2 & 2 & 1 & 0 & 0 & 1 \end{bmatrix}$$

Example

$$B = \{4, 1, 6\} \rightarrow \bar{B} = \{4, 1, 2\}$$

- 2 enters
- $6 = B(3)$ exists

Smarter linear system solution

Basis matrix change

$$A_{\bar{B}} = A_B + \overbrace{(A_i - A_j)}^v e_\ell^T$$



A_B

$$\left(A_B + v e_\ell^T \right)^{-1} = \left(I - \frac{1}{1 + e_\ell^T A_B^{-1} v} A_B^{-1} v e_\ell^T \right) A_B^{-1}$$

Matrix inversion lemma
(from homework 2)

Smarter linear system solution

Basis matrix change

$$A_{\bar{B}} = A_B + \overbrace{(A_i - A_j)}^v e_\ell^T \longrightarrow (A_B + v e_\ell^T)^{-1} = \left(I - \frac{1}{1 + e_\ell^T A_B^{-1} v} A_B^{-1} v e_\ell^T \right) A_B^{-1}$$

Matrix inversion lemma
(from homework 2)

Solve $A_{\bar{B}} d_{\bar{B}} = -A_j$

1. Solve $A_B z^1 = e_\ell$ ($2n^2$ flops)
2. Solve $A_B z^2 = -A_j$ ($2n^2$ flops)
3. Solve $d_{\bar{B}} = z^2 - \frac{v^T z^2}{1 + v^T z^1} z^1$

Smarter linear system solution

Basis matrix change

$$A_{\bar{B}} = A_B + \overbrace{(A_i - A_j)}^v e_\ell^T \longrightarrow (A_B + v e_\ell^T)^{-1} = \left(I - \frac{1}{1 + e_\ell^T A_B^{-1} v} A_B^{-1} v e_\ell^T \right) A_B^{-1}$$

Matrix inversion lemma
(from homework 2)

Solve $A_{\bar{B}} d_{\bar{B}} = -A_j$

1. Solve $A_B z^1 = e_\ell$ ($2n^2$ flops)
2. Solve $A_B z^2 = -A_j$ ($2n^2$ flops)
3. Solve $d_{\bar{B}} = z^2 - \frac{v^T z^2}{1 + v^T z^1} z^1$

Remarks

- Same complexity for $A_B^T p = c_B$ ($4n^2$ flops)
- k -th next iteration ($4kn^2$ flops, derive as exercise...)
- Once in a while (e.g., $k = 100$), better to refactor A_B

Complexity of a single simplex iteration

1. Compute the reduced costs \bar{c}
 - Solve $A_B^T p = c_B$
 - $\bar{c} = c - A^T p$
2. If $\bar{c} \geq 0$, x **optimal. break**
3. Choose j such that $\bar{c}_j < 0$
4. Compute search direction d with $d_j = 1$ and $A_B d_B = -A_j$
5. If $d_B \geq 0$, the problem is **unbounded** and the optimal value is $-\infty$. **break**
6. Compute step length $\theta^* = \min_{\{i \in B \mid d_i < 0\}} \left(-\frac{x_i}{d_i} \right)$
7. Define y such that $y = x + \theta^* d$
8. Get new basis \bar{B} (i exits and j enters)

Bottleneck
Two linear systems

Complexity of a single simplex iteration

1. Compute the reduced costs \bar{c}
 - Solve $A_B^T p = c_B$
 - $\bar{c} = c - A^T p$
2. If $\bar{c} \geq 0$, x **optimal. break**
3. Choose j such that $\bar{c}_j < 0$
4. Compute search direction d with $d_j = 1$ and $A_B d_B = -A_j$
5. If $d_B \geq 0$, the problem is **unbounded** and the optimal value is $-\infty$. **break**
6. Compute step length $\theta^* = \min_{\{i \in B \mid d_i < 0\}} \left(-\frac{x_i}{d_i} \right)$
7. Define y such that $y = x + \theta^* d$
8. Get new basis \bar{B} (i exits and j enters)

Bottleneck
Two linear systems



Matrix inversion lemma trick
 $\approx n^2$ per iteration
(very cheap)

Complexity of a single simplex iteration

1. Compute the reduced costs \bar{c}
 - Solve $A_B^T p = c_B$
 - $\bar{c} = c - A^T p$
2. If $\bar{c} \geq 0$, x **optimal. break**
3. Choose j such that $\bar{c}_j < 0$
4. Compute search direction d with $d_j = 1$ and $A_B d_B = -A_j$
5. If $d_B \geq 0$, the problem is **unbounded** and the optimal value is $-\infty$. **break**
6. Compute step length $\theta^* = \min_{\{i \in B \mid d_i < 0\}} \left(-\frac{x_i}{d_i} \right)$
7. Define y such that $y = x + \theta^* d$
8. Get new basis \bar{B} (i exits and j enters)

Bottleneck
Two linear systems

→

Matrix inversion lemma trick
 $\approx n^2$ per iteration
(very cheap)

How many iterations do we need?

Complexity of the simplex method

Example of worst-case behavior

Innocent-looking problem

$$\begin{array}{ll} \text{minimize} & -x_n \\ \text{subject to} & 0 \leq x \leq 1 \end{array}$$

2^n vertices

$2^n/2$ vertices: cost = 1
 $2^n/2$ vertices: cost = 0

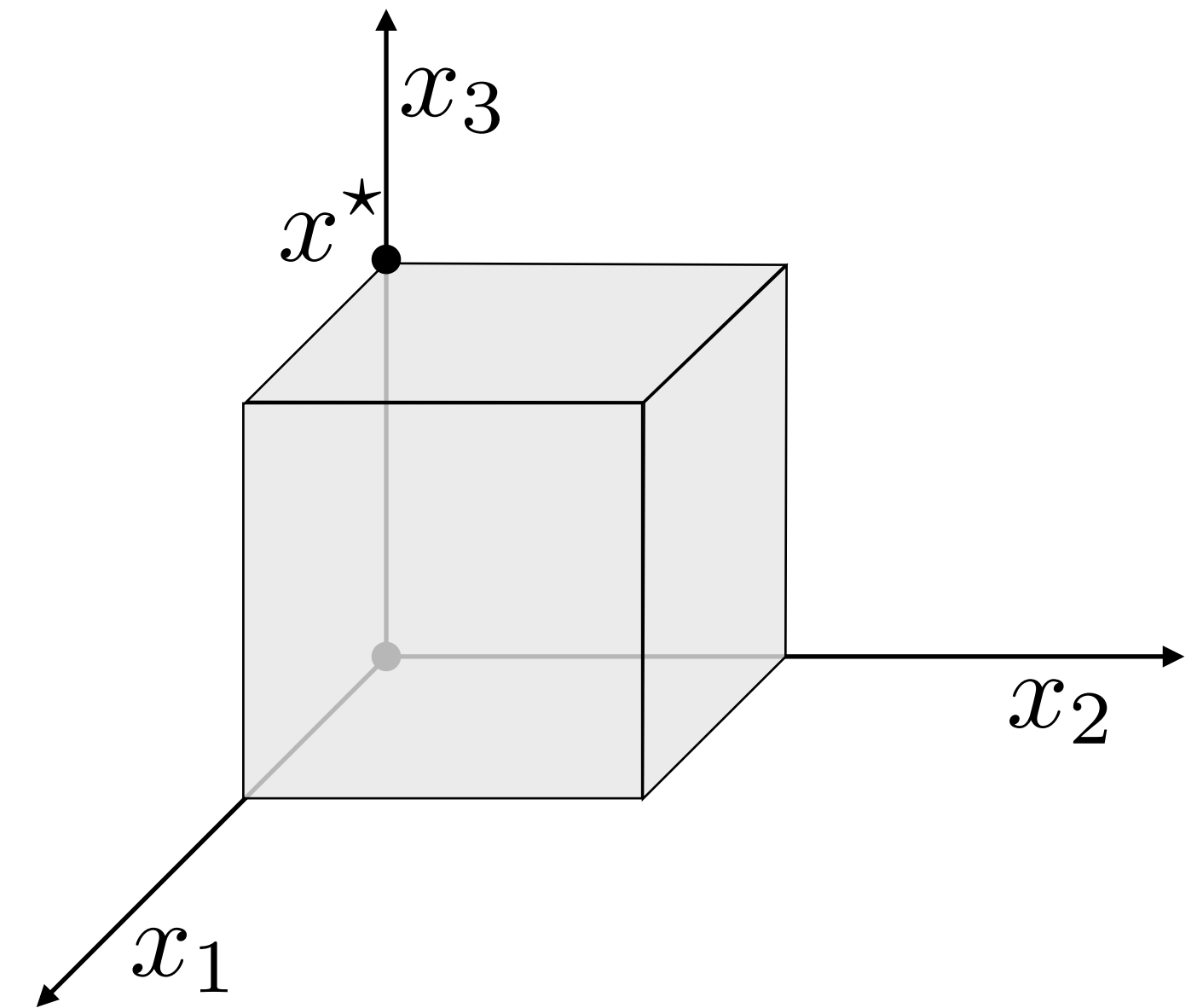

Complexity of the simplex method

Example of worst-case behavior

Innocent-looking problem

$$\begin{array}{ll} \text{minimize} & -x_n \\ \text{subject to} & 0 \leq x \leq 1 \end{array} \quad \begin{array}{l} 2^n \text{ vertices} \\ 2^{n-1} \text{ vertices: cost} = 1 \\ 2^{n-1} \text{ vertices: cost} = 0 \end{array}$$

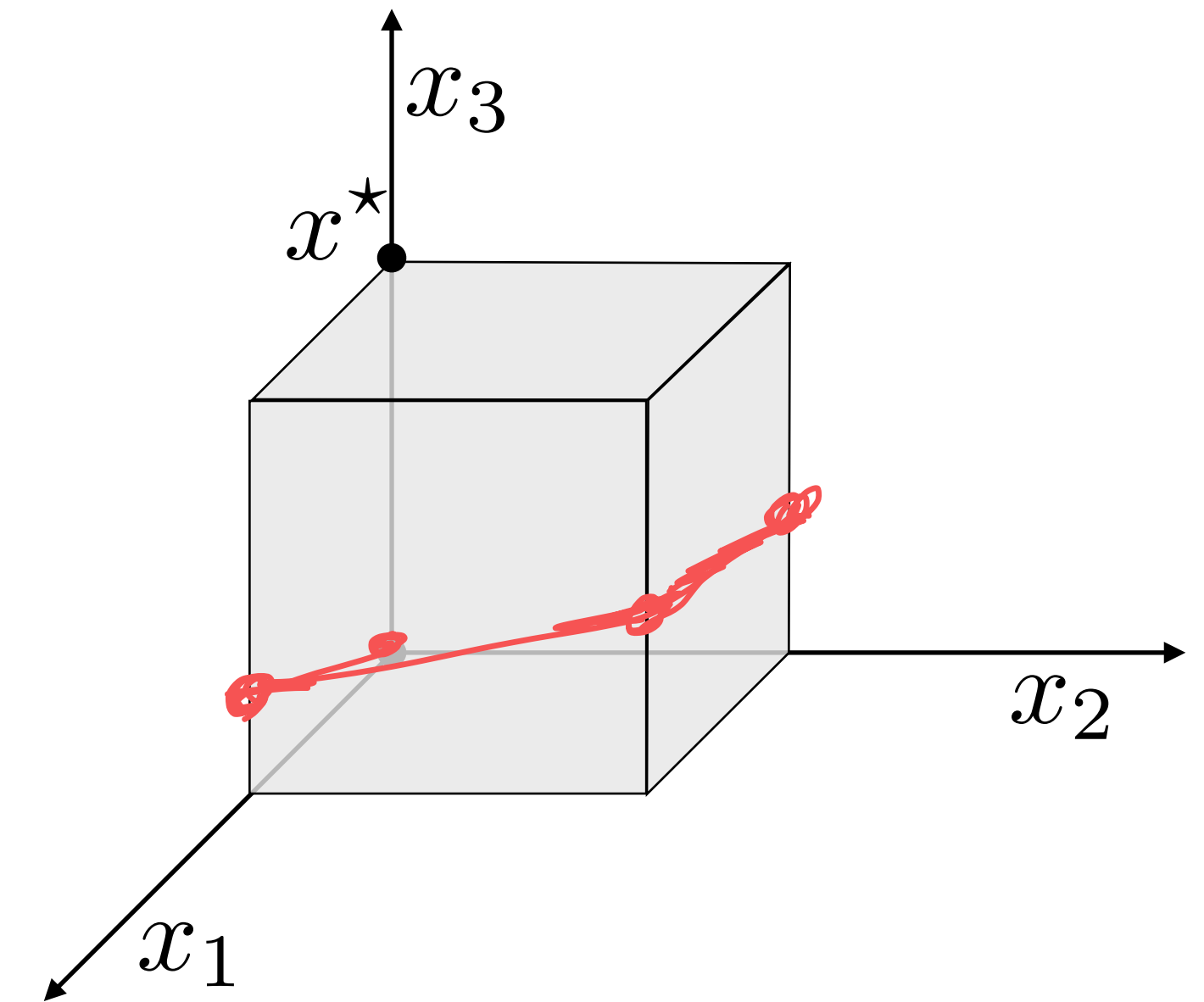

Perturb unit cube

$$\begin{array}{ll} \text{minimize} & -x_n \\ \text{subject to} & \epsilon \leq x_1 \leq 1 \\ & \epsilon x_{i-1} \leq x_i \leq 1 - \epsilon x_{i-1}, \quad i = 2, \dots, n \end{array}$$

Complexity of the simplex method

Example of worst-case behavior

minimize $-x_n$

subject to $\epsilon \leq x_1 \leq 1$

$$\epsilon x_{i-1} \leq x_i \leq 1 - \epsilon x_{i-1}, \quad i = 2, \dots, n$$

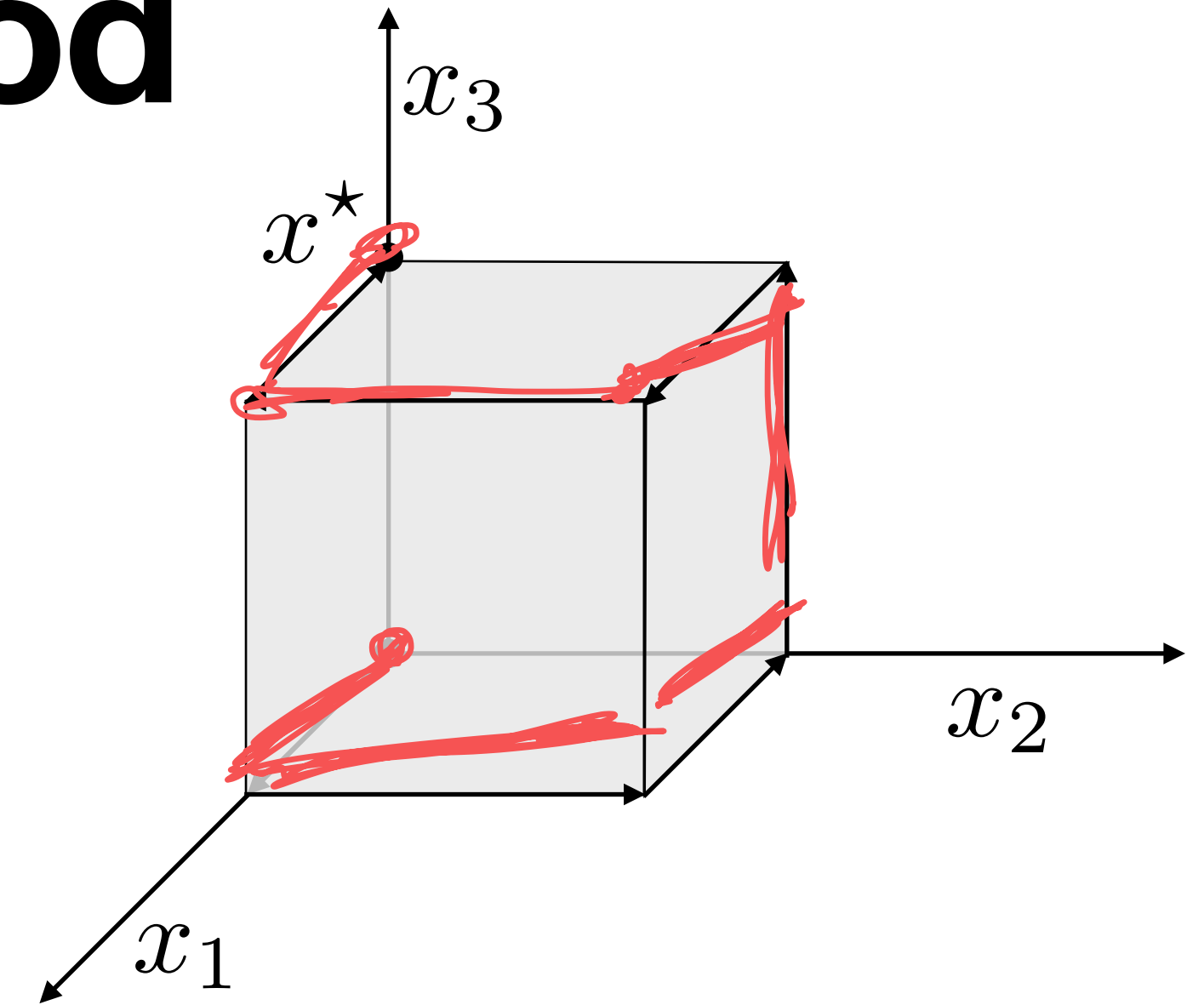

Complexity of the simplex method

Example of worst-case behavior

minimize $-x_n$

subject to $\epsilon \leq x_1 \leq 1$

$$\epsilon x_{i-1} \leq x_i \leq 1 - \epsilon x_{i-1}, \quad i = 2, \dots, n$$

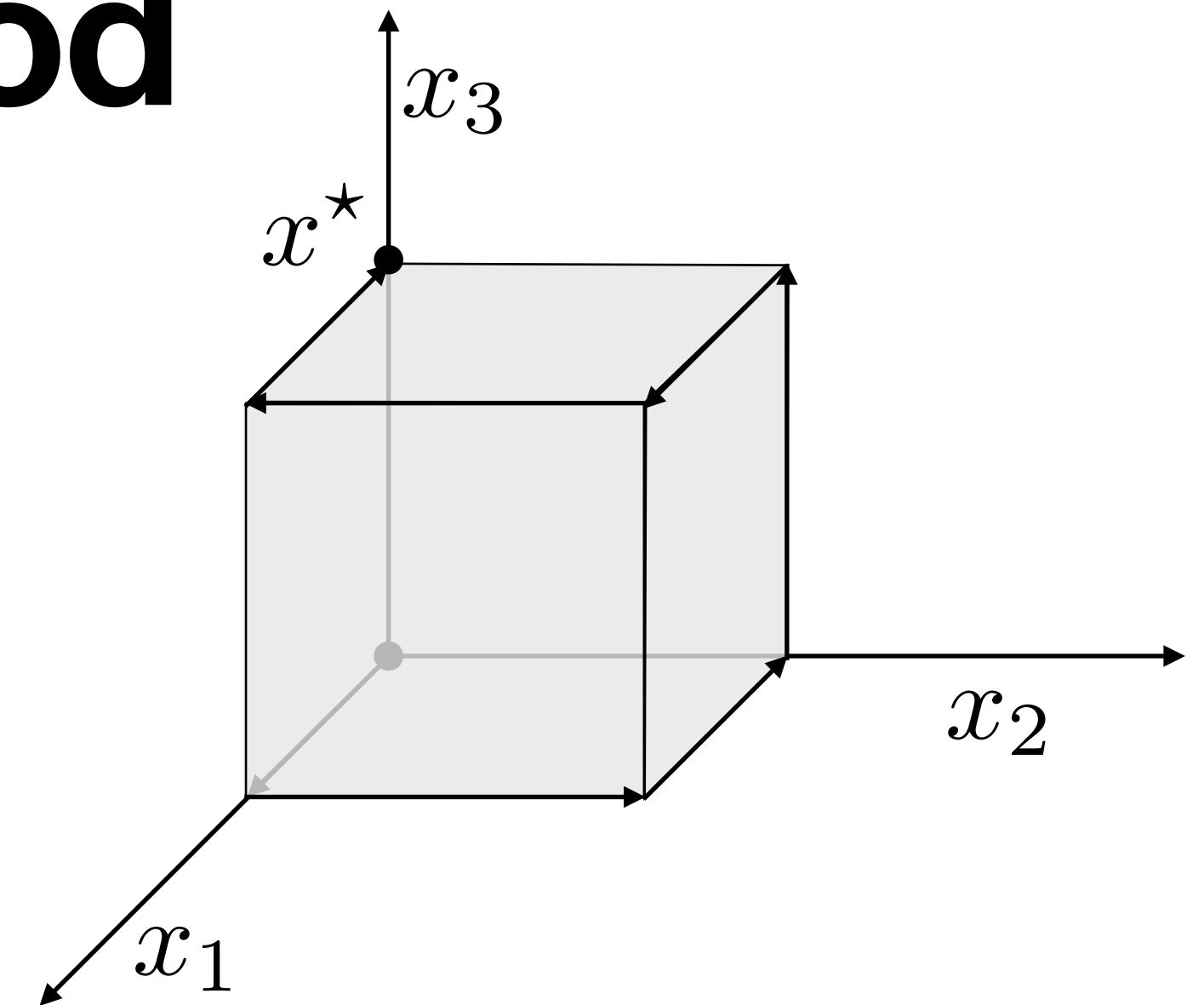

Theorem

- The vertices can be ordered so that each one is adjacent to and has a **lower cost than the previous one**
- There exists a pivoting rule under which the simplex method terminates after $2^n - 1$ **iterations**

Complexity of the simplex method

Example of worst-case behavior

$$\begin{aligned} \text{minimize} \quad & -x_n \\ \text{subject to} \quad & \epsilon \leq x_1 \leq 1 \\ & \epsilon x_{i-1} \leq x_i \leq 1 - \epsilon x_{i-1}, \quad i = 2, \dots, n \end{aligned}$$

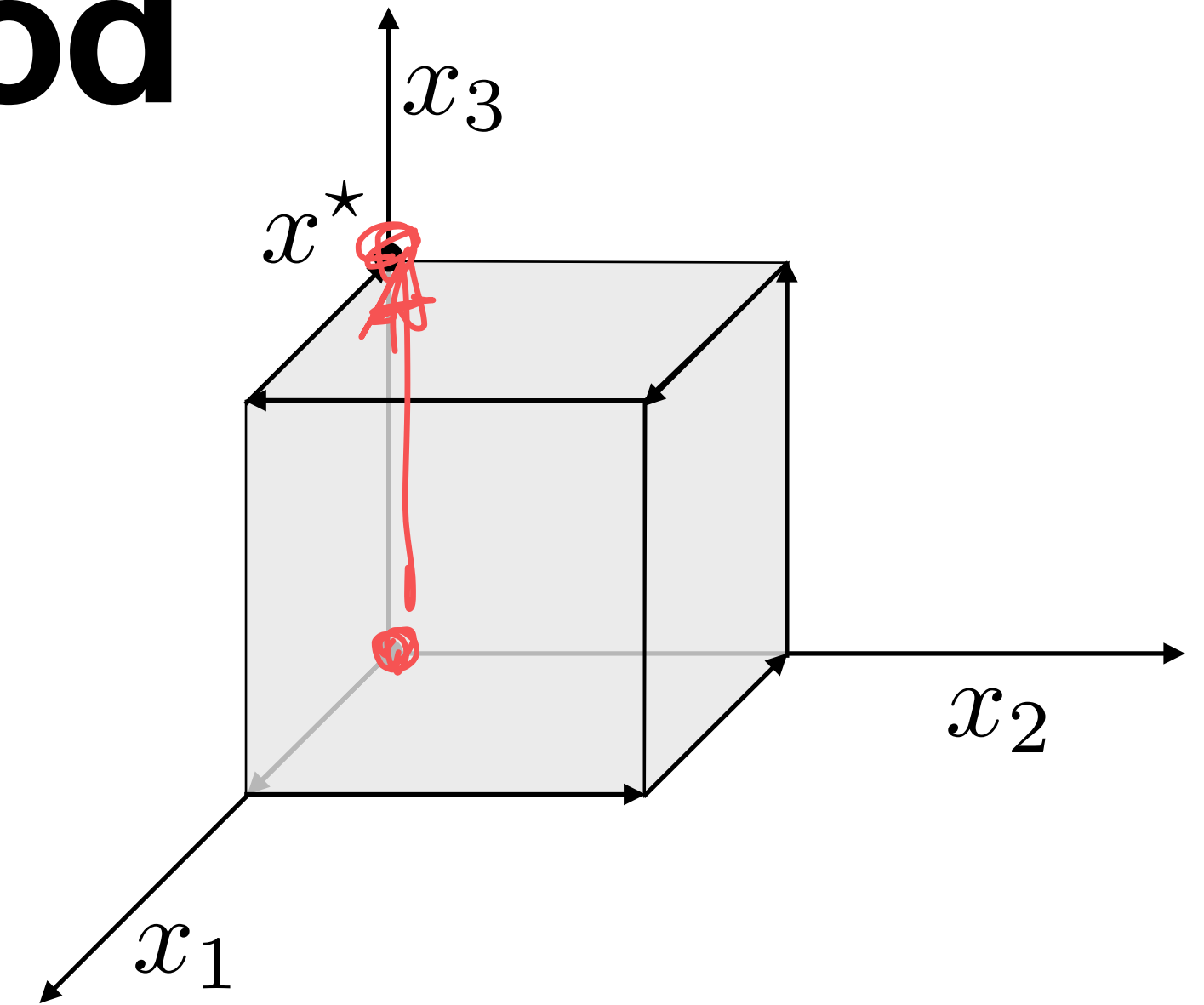

Theorem

- The vertices can be ordered so that each one is adjacent to and has a **lower cost than the previous one**
- There exists a pivoting rule under which the simplex method terminates after $2^n - 1$ **iterations**

Remark

- A **different pivot rule** would have converged in one iteration.
- We have a bad example for every pivot rule.

Complexity of the simplex method

We do not know any polynomial version of the simplex method, no matter which pivoting rule we pick.



Still open research question!

Complexity of the simplex method

We do not know any polynomial version of the simplex method, no matter which pivoting rule we pick.



Still open research question!

Worst-case

There are problem instances where the simplex method will run an **exponential number of iterations** in terms of the dimensions, e.g. 2^n

Complexity of the simplex method

We do not know any polynomial version of the simplex method, no matter which pivoting rule we pick. \longrightarrow Still open research question!

Worst-case

There are problem instances where the simplex method will run an **exponential number of iterations** in terms of the dimensions, e.g. 2^n

Good news: average-case

Practical performance is very good. On average, it stops in n iterations.

Average simplex complexity

Random LPs

minimize $c^T x$

n variables

subject to $Ax \leq b$

$3n$ constraints

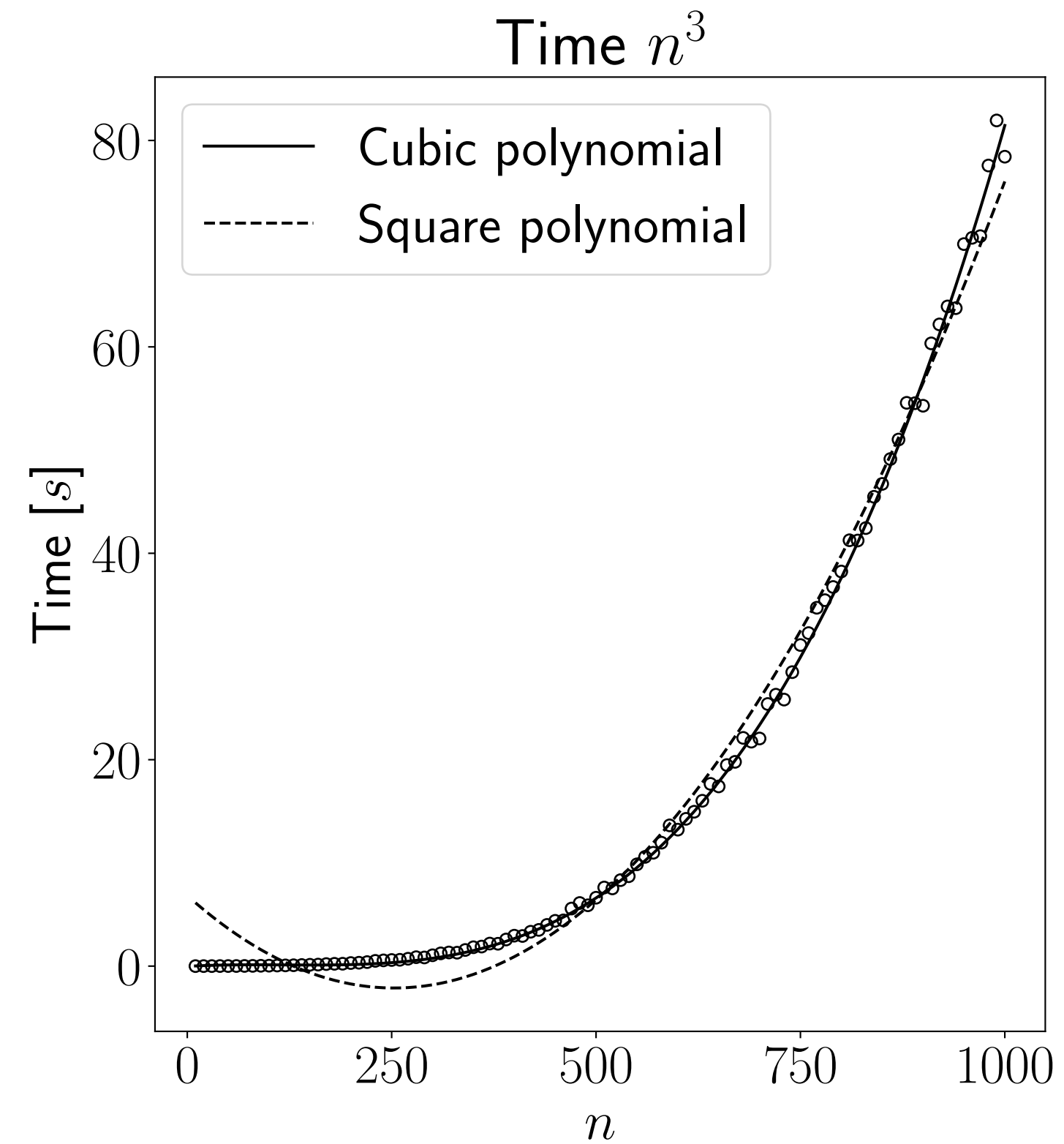
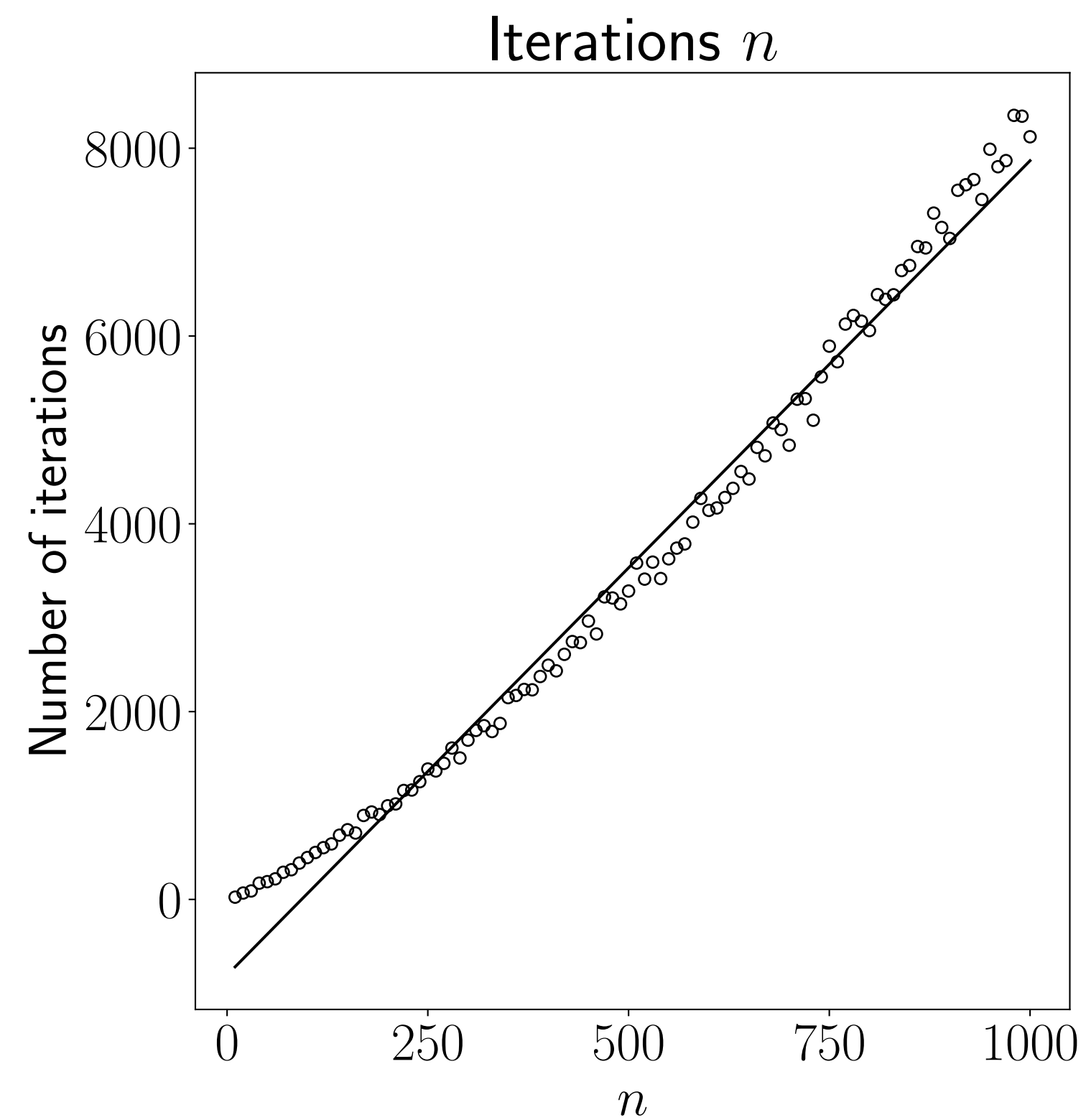

Recap

Linear optimization formulations

Standard form LP

$$\begin{array}{ll} \text{minimize} & c^T x \\ \text{subject to} & Ax = b \\ & x \geq 0 \end{array}$$

Inequality form LP

$$\begin{array}{ll} \text{minimize} & c^T x \\ \text{subject to} & Ax \leq b \end{array}$$

Today's agenda

Duality

- Obtaining lower bounds
- The dual problem
- Weak and strong duality

Obtaining lower bounds

Obtaining lower bounds

A simple example

$$\begin{array}{ll} \text{minimize} & x_1 + 3x_2 \\ \text{subject to} & x_1 + 3x_2 \geq 2 \end{array}$$

What is a **lower bound** on the optimal cost?

Obtaining lower bounds

A simple example

$$\begin{array}{ll} \text{minimize} & x_1 + 3x_2 \\ \text{subject to} & x_1 + 3x_2 \geq 2 \end{array}$$

What is a **lower bound** on the optimal cost?

A lower bound is 2 because $x_1 + 3x_2 \geq 2$

Obtaining lower bounds

Another example

$$\begin{array}{ll} \text{minimize} & x_1 + 3x_2 \\ \text{subject to} & x_1 + x_2 \geq 2 \\ & x_2 \geq 1 \end{array}$$

What is a **lower bound** on the optimal cost?

Obtaining lower bounds

Another example

$$\begin{aligned} \text{minimize} \quad & x_1 + 3x_2 \\ \text{subject to} \quad & x_1 + x_2 \geq 2 \\ & x_2 \geq 1 \end{aligned}$$

What is a **lower bound** on the optimal cost?

Let's sum the constraints

$$\begin{aligned} & 1 \cdot (x_1 + x_2 \geq 2) \\ & + 2 \cdot (x_2 \geq 1) \\ & = x_1 + 3x_2 \geq 4 \end{aligned}$$

Obtaining lower bounds

Another example

$$\begin{aligned} \text{minimize} \quad & x_1 + 3x_2 \\ \text{subject to} \quad & x_1 + x_2 \geq 2 \\ & x_2 \geq 1 \end{aligned}$$

What is a **lower bound** on the optimal cost?

Let's sum the constraints

$$\begin{aligned} & 1 \cdot (x_1 + x_2 \geq 2) \\ & + 2 \cdot (x_2 \geq 1) \\ & = x_1 + 3x_2 \geq 4 \end{aligned}$$

A lower bound is 4

Obtaining lower bounds

A more interesting example

$$\begin{array}{ll} \text{minimize} & x_1 + 3x_2 \\ \text{subject to} & x_1 + x_2 \geq 2 \\ & x_2 \geq 1 \\ & x_1 - x_2 \geq 3 \end{array}$$

How can we obtain a lower bound?

Obtaining lower bounds

A more interesting example

$$\begin{aligned} \text{minimize} \quad & x_1 + 3x_2 \\ \text{subject to} \quad & x_1 + x_2 \geq 2 \\ & x_2 \geq 1 \\ & x_1 - x_2 \geq 3 \end{aligned}$$

How can we obtain a lower bound?

Add constraints

$$\begin{aligned} & y_1 \cdot (x_1 + x_2 \geq 2) \\ + & y_2 \cdot (x_2 \geq 1) \\ + & y_3 \cdot (x_1 - x_2 \geq 3) \\ \Rightarrow & (y_1 + y_3)x_1 + (y_1 + y_2 - y_3)x_2 \geq 2y_1 + y_2 + 3y_3 \end{aligned}$$

Obtaining lower bounds

A more interesting example

$$\begin{aligned} \text{minimize} \quad & x_1 + 3x_2 \\ \text{subject to} \quad & x_1 + x_2 \geq 2 \\ & x_2 \geq 1 \\ & x_1 - x_2 \geq 3 \end{aligned}$$

How can we obtain a lower bound?

Add constraints

$$\begin{aligned} & y_1 \cdot (x_1 + x_2 \geq 2) \\ + & y_2 \cdot (x_2 \geq 1) \\ + & y_3 \cdot (x_1 - x_2 \geq 3) \\ \Rightarrow & (y_1 + y_3)x_1 + (y_1 + y_2 - y_3)x_2 \geq 2y_1 + y_2 + 3y_3 \end{aligned}$$

Bound

Obtaining lower bounds

A more interesting example

$$\begin{aligned} \text{minimize} \quad & x_1 + 3x_2 \\ \text{subject to} \quad & x_1 + x_2 \geq 2 \\ & x_2 \geq 1 \\ & x_1 - x_2 \geq 3 \end{aligned}$$

How can we obtain a lower bound?

Add constraints

$$\begin{aligned} & y_1 \cdot (x_1 + x_2 \geq 2) \\ + & y_2 \cdot (x_2 \geq 1) \\ + & y_3 \cdot (x_1 - x_2 \geq 3) \end{aligned}$$

$$\Rightarrow (y_1 + y_3)x_1 + (y_1 + y_2 - y_3)x_2 \geq 2y_1 + y_2 + 3y_3$$

Match cost coefficients

$$y_1 + y_3 = 1$$

$$y_1 + y_2 - y_3 = 3$$

$$y_1, y_2, y_3 \geq 0$$

Bound

Obtaining lower bounds

A more interesting example

$$\begin{aligned} \text{minimize} \quad & x_1 + 3x_2 \\ \text{subject to} \quad & x_1 + x_2 \geq 2 \\ & x_2 \geq 1 \\ & x_1 - x_2 \geq 3 \end{aligned}$$

How can we obtain a lower bound?

Add constraints

$$\begin{aligned} & y_1 \cdot (x_1 + x_2 \geq 2) \\ + & y_2 \cdot (x_2 \geq 1) \\ + & y_3 \cdot (x_1 - x_2 \geq 3) \end{aligned}$$

$$\Rightarrow (y_1 + y_3)x_1 + (y_1 + y_2 - y_3)x_2 \geq 2y_1 + y_2 + 3y_3$$

Match cost coefficients

$$y_1 + y_3 = 1$$

$$y_1 + y_2 - y_3 = 3$$

$$y_1, y_2, y_3 \geq 0$$

Bound

Many options

$$y = (1, 2, 0) \Rightarrow \text{Bound } 4$$

Obtaining lower bounds

A more interesting example

$$\begin{aligned} \text{minimize} \quad & x_1 + 3x_2 \\ \text{subject to} \quad & x_1 + x_2 \geq 2 \\ & x_2 \geq 1 \\ & x_1 - x_2 \geq 3 \end{aligned}$$

How can we obtain a lower bound?

Add constraints

$$\begin{aligned} & y_1 \cdot (x_1 + x_2 \geq 2) \\ + & y_2 \cdot (x_2 \geq 1) \\ + & y_3 \cdot (x_1 - x_2 \geq 3) \end{aligned}$$

$$\Rightarrow (y_1 + y_3)x_1 + (y_1 + y_2 - y_3)x_2 \geq 2y_1 + y_2 + 3y_3$$

Match cost coefficients

$$y_1 + y_3 = 1$$

$$y_1 + y_2 - y_3 = 3$$

$$y_1, y_2, y_3 \geq 0$$

Bound

Many options

$$\begin{aligned} y = (1, 2, 0) &\Rightarrow \text{Bound 4} \\ y = (0, 4, 1) &\Rightarrow \text{Bound 7} \end{aligned}$$

Obtaining lower bounds

A more interesting example

$$\begin{aligned} \text{minimize} \quad & x_1 + 3x_2 \\ \text{subject to} \quad & x_1 + x_2 \geq 2 \\ & x_2 \geq 1 \\ & x_1 - x_2 \geq 3 \end{aligned}$$

How can we obtain a lower bound?

Add constraints

$$\begin{aligned} & y_1 \cdot (x_1 + x_2 \geq 2) \\ + & y_2 \cdot (x_2 \geq 1) \\ + & y_3 \cdot (x_1 - x_2 \geq 3) \end{aligned}$$

$$\Rightarrow (y_1 + y_3)x_1 + (y_1 + y_2 - y_3)x_2 \geq 2y_1 + y_2 + 3y_3$$

Match cost coefficients

$$y_1 + y_3 = 1$$

$$y_1 + y_2 - y_3 = 3$$

$$y_1, y_2, y_3 \geq 0$$

Bound

Many options

$$y = (1, 2, 0) \Rightarrow \text{Bound } 4$$

$$y = (0, 4, 1) \Rightarrow \text{Bound } 7$$

How can we get the **best one**?

$$x_1 + 3x_2 \geq 4$$

Obtaining lower bounds

A more interesting example – Best lower bound

We can obtain the **best lower bound** by solving the following problem

$$\begin{array}{ll} \text{maximize} & 2y_1 + y_2 + 3y_3 \\ \text{subject to} & y_1 + y_3 = 1 \\ & y_1 + y_2 - y_3 = 3 \\ & y_1, y_2, y_3 \geq 0 \end{array}$$

Obtaining lower bounds

A more interesting example – Best lower bound

We can obtain the **best lower bound** by solving the following problem

$$\begin{aligned} &\text{maximize} && 2y_1 + y_2 + 3y_3 \\ &\text{subject to} && y_1 + y_3 = 1 \\ & && y_1 + y_2 - y_3 = 3 \\ & && y_1, y_2, y_3 \geq 0 \end{aligned}$$

This linear optimization problem is called the **dual problem**

The dual problem

Lagrange multipliers

Consider the LP in standard form

minimize $c^T x$

subject to $Ax = b$

$x \geq 0$

Lagrange multipliers

Consider the LP in standard form

$$\begin{array}{ll} \text{minimize} & c^T x \\ \text{subject to} & Ax = b \\ & x \geq 0 \end{array}$$

Relax the constraint

$$g(y) = \begin{array}{ll} \text{minimize} & c^T x + y^T (Ax - b) \\ & x \\ \text{subject to} & x \geq 0 \end{array}$$

Lagrange multipliers

Consider the LP in standard form

$$\begin{aligned} &\text{minimize} && c^T x \\ &\text{subject to} && Ax = b \\ &&& x \geq 0 \end{aligned}$$

Relax the constraint

$$g(y) = \begin{aligned} &\text{minimize} && c^T x + y^T (Ax - b) \\ &&& \text{subject to} && x \geq 0 \end{aligned}$$

Lower bound

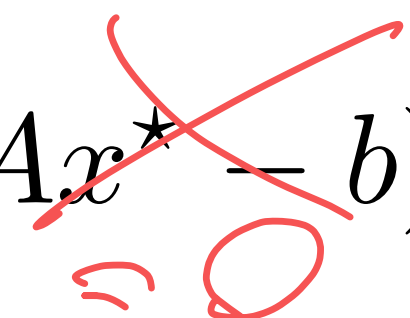
$$g(y) \leq c^T x^* + y^T (Ax^* - b) = c^T x^*$$

Lagrange multipliers

Consider the LP in standard form

$$\begin{aligned} &\text{minimize} && c^T x \\ &\text{subject to} && Ax = b \\ &&& x \geq 0 \end{aligned}$$

Lower bound

$$g(y) \leq c^T x^* + y^T (Ax^* - b) = c^T x^*$$

Relax the constraint

$$g(y) = \begin{aligned} &\text{minimize} && c^T x + y^T (Ax - b) \\ &&& \text{subject to} && x \geq 0 \end{aligned}$$

Best lower bound

$$\text{maximize}_y g(y)$$

The dual

Dual function

$$\begin{aligned} g(y) &= \underset{x \geq 0}{\text{minimize}} (c^T x + y^T (Ax - b)) \\ &= -b^T y + \underset{x \geq 0}{\text{minimize}} (c + A^T y)^T x \end{aligned}$$

The dual

$$c = (2 \ 3)$$

$$\begin{aligned} \min \quad & 2x_1 + 3x_2 - 2x_3 \\ \text{s.t.} \quad & x_1 \geq 0, x_2 \geq 0 \end{aligned}$$

Dual function

$$\begin{aligned} g(y) &= \underset{x \geq 0}{\text{minimize}} (c^T x + y^T (Ax - b)) \\ &= -b^T y + \underset{x \geq 0}{\text{minimize}} \underbrace{(c + A^T y)^T}_{\text{red underline}} x \end{aligned}$$

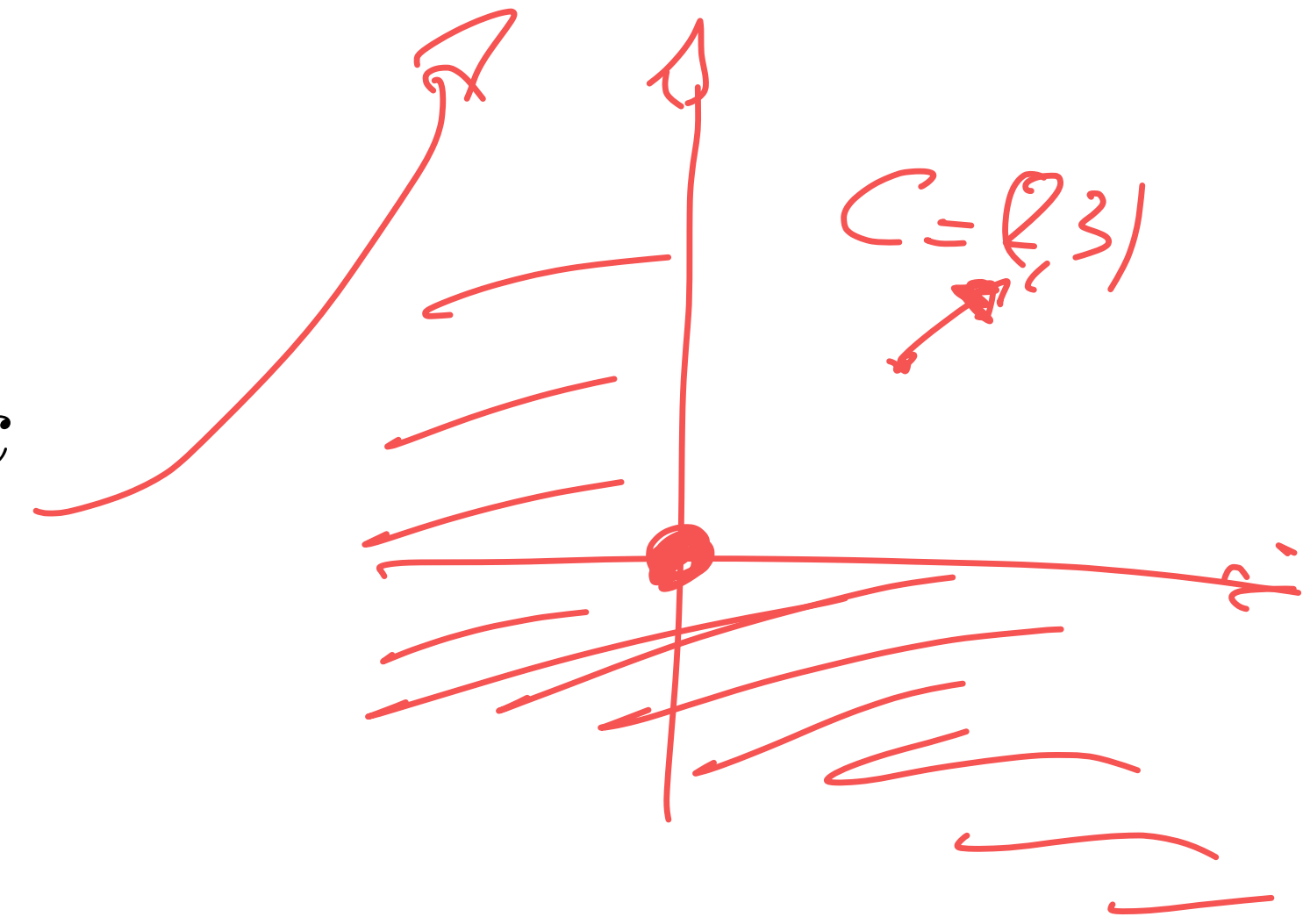

$$g(y) = \begin{cases} -b^T y & \text{if } c + A^T y \geq 0 \\ -\infty & \text{otherwise} \end{cases}$$

The dual

Dual function

$$\begin{aligned} g(y) &= \underset{x \geq 0}{\text{minimize}} (c^T x + y^T (Ax - b)) \\ &= -b^T y + \underset{x \geq 0}{\text{minimize}} (c + A^T y)^T x \end{aligned}$$

$$g(y) = \begin{cases} -b^T y & \text{if } c + A^T y \geq 0 \\ -\infty & \text{otherwise} \end{cases}$$

Dual problem (find the best bound)

$$\begin{aligned} \underset{y}{\text{maximize}} \quad g(y) &= \underset{y}{\text{maximize}} \quad -b^T y \\ &\text{subject to} \quad A^T y + c \geq 0 \end{aligned}$$

$$A \in \mathbb{R}^{m \times n}$$

Primal and dual problems

Primal problem

$$\begin{aligned} &\text{minimize} && c^T x \\ &\text{subject to} && Ax = b \\ &&& x \geq 0 \end{aligned}$$

Primal variable $x \in \mathbf{R}^n$

Dual problem

$$\begin{aligned} &\text{maximize} && -b^T y \\ &\text{subject to} && A^T y + c \geq 0 \end{aligned}$$

Dual variable $y \in \mathbf{R}^m$

Primal and dual problems

Primal problem

$$\begin{aligned} &\text{minimize} && c^T x \\ &\text{subject to} && Ax = b \\ &&& x \geq 0 \end{aligned}$$

Primal variable $x \in \mathbf{R}^n$

Dual problem

$$\begin{aligned} &\text{maximize} && -b^T y \\ &\text{subject to} && A^T y + c \geq 0 \end{aligned}$$

Dual variable $y \in \mathbf{R}^m$

The dual problem carries **useful information** for the primal problem

Primal and dual problems

Primal problem

$$\begin{aligned} &\text{minimize} && c^T x \\ &\text{subject to} && Ax = b \\ &&& x \geq 0 \end{aligned}$$

Primal variable $x \in \mathbf{R}^n$

Dual problem

$$\begin{aligned} &\text{maximize} && -b^T y \\ &\text{subject to} && A^T y + c \geq 0 \end{aligned}$$

Dual variable $y \in \mathbf{R}^m$

The dual problem carries **useful information** for the primal problem

Duality is useful also to **solve** optimization problems

Dual of inequality form LP

What if you find an LP with inequalities?

$$\begin{array}{ll} \text{minimize} & c^T x \\ \text{subject to} & Ax \leq b \end{array}$$

Dual of inequality form LP

What if you find an LP with inequalities?

$$\begin{array}{ll} \text{minimize} & c^T x \\ \text{subject to} & Ax \leq b \end{array}$$

1. We could first transform it to standard form

Dual of inequality form LP

What if you find an LP with inequalities?

$$\begin{array}{ll} \text{minimize} & c^T x \\ \text{subject to} & Ax \leq b \end{array}$$

1. We could first transform it to standard form
2. We can compute the dual function (same procedure as before)

Relax the constraint

$$g(y) = \underset{x}{\text{minimize}} \quad c^T x + y^T (Ax - b)$$

Dual of inequality form LP

What if you find an LP with inequalities?

$$\begin{array}{ll} \text{minimize} & c^T x \\ \text{subject to} & Ax \leq b \end{array}$$

1. We could first transform it to standard form
2. We can compute the dual function (same procedure as before)

Relax the constraint

$$g(y) = \underset{x}{\text{minimize}} \quad c^T x + y^T (Ax - b)$$

Lower bound

$$g(y) \leq c^T x^* + y^T (Ax^* - b) \leq c^T x^*$$

we must have $y \geq 0$

Dual of LP with inequalities

Derivation

Dual function

$$\begin{aligned} g(y) &= \underset{x}{\text{minimize}} (c^T x + y^T (Ax - b)) \\ &= -b^T y + \underset{x}{\text{minimize}} (c + A^T y)^T x \end{aligned}$$

Dual of LP with inequalities

Derivation

Dual function

$$\begin{aligned} g(y) &= \underset{x}{\text{minimize}} (c^T x + y^T (Ax - b)) \\ &= -b^T y + \underset{x}{\text{minimize}} (c + A^T y)^T x \end{aligned}$$

$$g(y) = \begin{cases} -b^T y & \text{if } c + A^T y = 0 \quad (\text{and } y \geq 0) \\ -\infty & \text{otherwise} \end{cases}$$

Dual of LP with inequalities

Derivation

Dual function

$$\begin{aligned} g(y) &= \underset{x}{\text{minimize}} (c^T x + y^T (Ax - b)) \\ &= -b^T y + \underset{x}{\text{minimize}} (c + A^T y)^T x \end{aligned}$$

$$g(y) = \begin{cases} -b^T y & \text{if } c + A^T y = 0 \quad (\text{and } y \geq 0) \\ -\infty & \text{otherwise} \end{cases}$$

Dual problem (find the best bound)

$$\begin{aligned} \underset{y}{\text{maximize}} \quad g(y) &= \text{maximize} \quad -b^T y \\ &\text{subject to} \quad A^T y + c = 0 \\ &\quad \quad \quad y \geq 0 \end{aligned}$$

General forms

	Standard form LP		
Primal		Dual	
minimize	$c^T x$	maximize	$-b^T y$
subject to	$Ax = b$	subject to	$A^T y + c \geq 0$
	$x \geq 0$		
Primal	Inequality form LP	Dual	
minimize	$c^T x$	maximize	$-b^T y$
subject to	$Ax \leq b$	subject to	$A^T y + c = 0$
			$y \geq 0$

General forms

		Standard form LP		
Primal			Dual	
minimize	$c^T x$		maximize	$-b^T y$
subject to	$Ax = b$		subject to	$A^T y + c \geq 0$
	$x \geq 0$			

		Inequality form LP		
Primal			Dual	
minimize	$c^T x$		maximize	$-b^T y$
subject to	$Ax \leq b$		subject to	$A^T y + c = 0$
				$y \geq 0$

		LP with inequalities and equalities		
Primal			Dual	
minimize	$c^T x$		maximize	$-b^T y - d^T z$
subject to	$Ax \leq b$ (y)		subject to	$A^T y + C^T z + c = 0$
	$Cx = d$ (z)			$y \geq 0$

Example from before

minimize $x_1 + 3x_2$

subject to $x_1 + x_2 \geq 2$

$x_2 \geq 1$

$x_1 - x_2 \geq 3$



Example from before

$$\begin{array}{ll} \text{minimize} & x_1 + 3x_2 \\ \text{subject to} & x_1 + x_2 \geq 2 \\ & x_2 \geq 1 \\ & x_1 - x_2 \geq 3 \end{array}$$



Inequality form LP

$$\begin{array}{ll} \text{minimize} & c^T x \\ \text{subject to} & Ax \leq b \end{array}$$

$$c = (1, 3)$$

$$A = \begin{bmatrix} -1 & -1 \\ 0 & -1 \\ -1 & 1 \end{bmatrix}$$

$$b = (-2, -1, -3)$$

Example from before

$$\begin{array}{ll} \text{minimize} & x_1 + 3x_2 \\ \text{subject to} & x_1 + x_2 \geq 2 \\ & x_2 \geq 1 \\ & x_1 - x_2 \geq 3 \end{array}$$



Inequality form LP

$$\begin{array}{ll} \text{minimize} & c^T x \\ \text{subject to} & Ax \leq b \end{array}$$

$$c = (1, 3)$$

$$A = \begin{bmatrix} -1 & -1 \\ 0 & -1 \\ -1 & 1 \end{bmatrix}$$

$$b = (-2, -1, -3)$$

Dual

$$\begin{array}{ll} \text{maximize} & -b^T y \\ \text{subject to} & A^T y + c = 0 \\ & y \geq 0 \end{array}$$

Example from before

$$\begin{array}{ll} \text{minimize} & x_1 + 3x_2 \\ \text{subject to} & x_1 + x_2 \geq 2 \\ & x_2 \geq 1 \\ & x_1 - x_2 \geq 3 \end{array}$$



Inequality form LP

$$\begin{array}{ll} \text{minimize} & c^T x \\ \text{subject to} & Ax \leq b \end{array}$$

$$c = (1, 3)$$

$$A = \begin{bmatrix} -1 & -1 \\ 0 & -1 \\ -1 & 1 \end{bmatrix}$$

$$b = (-2, -1, -3)$$

Dual

$$\begin{array}{ll} \text{maximize} & -b^T y \\ \text{subject to} & A^T y + c = 0 \\ & y \geq 0 \end{array}$$



$$\begin{array}{ll} \text{maximize} & 2y_1 + y_2 + 3y_3 \\ \text{subject to} & -y_1 - y_3 = -1 \\ & -y_1 - y_2 + y_3 = -3 \\ & y_1, y_2, y_3 \geq 0 \end{array}$$

To memorize

Ways to get the dual

- Derive dual function directly
- Transform the problem in inequality form LP and dualize

Sanity-checks and signs convention

- Consider constraints as $Ax - b \leq 0$ or $Ax - b = 0$ (not ≥ 0)
- Each dual variable is associated to a primal constraint
- y free for primal equalities and $y \geq 0$ for primal inequalities

Dual of the dual

Theorem

If we transform the primal into its dual and then transform the dual to its dual, we obtain a problem equivalent to the original problem. In other words, the **dual of the dual is the primal**.

Dual of the dual

Theorem

If we transform the primal into its dual and then transform the dual to its dual, we obtain a problem equivalent to the original problem. In other words, the **dual of the dual is the primal**.

Exercise

Derive dual and dualize again

Primal

$$\begin{aligned} &\text{minimize} && c^T x \\ &\text{subject to} && Ax \leq b \\ &&& Cx = d \end{aligned}$$

Dual

$$\begin{aligned} &\text{maximize} && -b^T y - d^T z \\ &\text{subject to} && A^T y + C^T z + c = 0 \\ &&& y \geq 0 \end{aligned}$$

Dual of the dual

Theorem

If we transform the primal into its dual and then transform the dual to its dual, we obtain a problem equivalent to the original problem. In other words, the **dual of the dual is the primal**.

Exercise

Derive dual and dualize again

Primal		Dual	
minimize	$c^T x$	maximize	$-b^T y - d^T z$
subject to	$Ax \leq b$	subject to	$A^T y + C^T z + c = 0$
	$Cx = d$		$y \geq 0$

Theorem

If we **transform a linear optimization problem to another form** (inequality form, standard form, inequality and equality form), **the dual of the two problems will be equivalent**.

Weak and strong duality

Optimal objective values

Primal

$$\begin{aligned} &\text{minimize} && c^T x \\ &\text{subject to} && Ax \leq b \end{aligned}$$

p^* is the primal optimal value

Primal infeasible: $p^* = +\infty$

Primal unbounded: $p^* = -\infty$

Dual

$$\begin{aligned} &\text{maximize} && -b^T y \\ &\text{subject to} && A^T y + c = 0 \\ &&& y \geq 0 \end{aligned}$$

d^* is the dual optimal value

Dual infeasible: $d^* = -\infty$

Dual unbounded: $d^* = +\infty$

Weak duality

Theorem

If x, y satisfy:

- x is a feasible solution to the primal problem
 - y is a feasible solution to the dual problem
- $-b^T y \leq c^T x$

Weak duality

Theorem

If x, y satisfy:

- x is a feasible solution to the primal problem
 - y is a feasible solution to the dual problem
- $\longrightarrow -b^T y \leq c^T x$

Proof

We know that $Ax \leq b$, $A^T y + c = 0$ and $y \geq 0$. Therefore,

$$0 \leq \underbrace{y^T}_{\geq 0} (\underbrace{b - Ax}_{\geq 0}) = b^T y - \underbrace{y^T Ax}_{= c^T x} = c^T x + b^T y$$

■

Weak duality

Theorem

If x, y satisfy:

- x is a feasible solution to the primal problem
 - y is a feasible solution to the dual problem
- $\longrightarrow -b^T y \leq c^T x$

Proof

We know that $Ax \leq b$, $A^T y + c = 0$ and $y \geq 0$. Therefore,

$$0 \leq y^T (b - Ax) = b^T y - y^T Ax = c^T x + b^T y \quad \blacksquare$$

Remark

- Any dual feasible y gives a **lower bound** on the primal optimal value
- Any primal feasible x gives an **upper bound** on the dual optimal value
- $c^T x + b^T y$ is the **duality gap**

Weak duality

Corollaries

Unboundedness vs feasibility

- Primal unbounded ($p^* = -\infty$) \Rightarrow dual infeasible ($d^* = -\infty$)
- Dual unbounded ($d^* = +\infty$) \Rightarrow primal infeasible ($p^* = +\infty$)

Weak duality

Corollaries

Unboundedness vs feasibility

- Primal unbounded ($p^* = -\infty$) \Rightarrow dual infeasible ($d^* = -\infty$)
- Dual unbounded ($d^* = +\infty$) \Rightarrow primal infeasible ($p^* = +\infty$)

Optimality condition

If x, y satisfy:

- x is a feasible solution to the primal problem
- y is a feasible solution to the dual problem
- The duality gap is zero, *i.e.*, $c^T x + b^T y = 0$

Then x and y are **optimal solutions** to the primal and dual problem respectively

Strong duality

Theorem

If a linear optimization problem has an optimal solution, so does its dual, and the optimal value of primal and dual are equal

$$d^* = p^*$$

Strong duality

Constructive proof

Given a primal optimal solution x^* we will construct a dual optimal solution y^*

Strong duality

Constructive proof

Given a primal optimal solution x^* we will construct a dual optimal solution y^*

Apply simplex to problem in **standard form**

$$\begin{array}{ll} \text{minimize} & c^T x \\ \text{subject to} & Ax = b \\ & x \geq 0 \end{array}$$

Strong duality

Constructive proof

Given a primal optimal solution x^* we will construct a dual optimal solution y^*

Apply simplex to problem in **standard form**

$$\begin{array}{ll} \text{minimize} & c^T x \\ \text{subject to} & Ax = b \\ & x \geq 0 \end{array} \longrightarrow \begin{array}{l} \bullet \text{ optimal basis } B \\ \bullet \text{ optimal solution } x^* \text{ with } A_B x_B^* = b \\ \bullet \text{ reduced costs } \bar{c} = c - A^T A_B^{-T} c_B \geq 0 \end{array}$$

Strong duality

Constructive proof

Given a primal optimal solution x^* we will construct a dual optimal solution y^*

Apply simplex to problem in **standard form**

$$\begin{array}{ll} \text{minimize} & c^T x \\ \text{subject to} & Ax = b \\ & x \geq 0 \end{array} \longrightarrow \begin{array}{l} \bullet \text{ optimal basis } B \\ \bullet \text{ optimal solution } x^* \text{ with } A_B x_B^* = b \\ \bullet \text{ reduced costs } \bar{c} = c - A^T A_B^{-T} c_B \geq 0 \end{array}$$

Define y^* such that $y^* = -A_B^{-T} c_B$. Therefore, $A^T y^* + c \geq 0$ (y^* dual feasible).

Strong duality

Constructive proof

Given a primal optimal solution x^* we will construct a dual optimal solution y^*

Apply simplex to problem in **standard form**

$$\begin{array}{ll} \text{minimize} & c^T x \\ \text{subject to} & Ax = b \\ & x \geq 0 \end{array} \longrightarrow \begin{array}{l} \bullet \text{ optimal basis } B \\ \bullet \text{ optimal solution } x^* \text{ with } A_B x_B^* = b \\ \bullet \text{ reduced costs } \bar{c} = c - A^T A_B^{-T} c_B \geq 0 \end{array}$$

Define y^* such that $y^* = -A_B^{-T} c_B$. Therefore, $A^T y^* + c \geq 0$ (y^* dual feasible).

$$-b^T y^* = -b^T (-A_B^{-T} c_B) = c_B^T (A_B^{-1} b) = c_B^T x_B^* = c^T x^*$$

Strong duality

Constructive proof

Given a primal optimal solution x^* we will construct a dual optimal solution y^*

Apply simplex to problem in **standard form**

$$\begin{array}{ll} \text{minimize} & c^T x \\ \text{subject to} & Ax = b \\ & x \geq 0 \end{array} \longrightarrow \begin{array}{l} \bullet \text{ optimal basis } B \\ \bullet \text{ optimal solution } x^* \text{ with } A_B x_B^* = b \\ \bullet \text{ reduced costs } \bar{c} = c - A^T A_B^{-T} c_B \geq 0 \end{array}$$

Define y^* such that $y^* = -A_B^{-T} c_B$. Therefore, $A^T y^* + c \geq 0$ (y^* dual feasible).

$$-b^T y^* = -b^T (-A_B^{-T} c_B) = c_B^T (A_B^{-1} b) = c_B^T x_B^* = c^T x^*$$

By weak duality theorem corollary, y^* is an optimal solution of the dual.

Therefore, $d^* = p^*$.

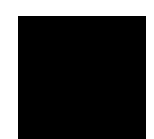

Exception to strong duality

Primal

$$\begin{array}{ll} \text{minimize} & x \\ \text{subject to} & 0 \cdot x \leq -1 \end{array}$$

Optimal value is $p^* = +\infty$

Dual

$$\begin{array}{ll} \text{maximize} & y \\ \text{subject to} & 0 \cdot y + 1 = 0 \\ & y \geq 0 \end{array}$$

Optimal value is $d^* = -\infty$

Exception to strong duality

Primal

$$\begin{array}{ll} \text{minimize} & x \\ \text{subject to} & 0 \cdot x \leq -1 \end{array}$$

Optimal value is $p^* = +\infty$

Dual

$$\begin{array}{ll} \text{maximize} & y \\ \text{subject to} & 0 \cdot y + 1 = 0 \\ & y \geq 0 \end{array}$$

Optimal value is $d^* = -\infty$

Both **primal** and **dual infeasible**

Relationship between primal and dual

	$p^* = +\infty$	p^* finite	$p^* = -\infty$
$d^* = +\infty$	primal inf. dual unb.		
d^* finite		optimal values equal	
$d^* = -\infty$	exception		primal unb. dual inf

- Upper-right excluded by **weak duality**
- (1, 1) and (3, 3) proven by **weak duality**
- (3, 1) and (2, 2) proven by **strong duality**

Example

Production problem

maximize $x_1 + 2x_2$

subject to $x_1 \leq 100$

$$2x_2 \leq 200$$

$$x_1 + x_2 \leq 150$$

$$x_1, x_2 \geq 0$$

Production problem

maximize $x_1 + 2x_2$ ← Profits

subject to $x_1 \leq 100$

$$2x_2 \leq 200$$

$$x_1 + x_2 \leq 150$$

$$x_1, x_2 \geq 0$$

Production problem

maximize $x_1 + 2x_2$ ← Profits

subject to $x_1 \leq 100$

$2x_2 \leq 200$ ← Resources

$x_1 + x_2 \leq 150$

$x_1, x_2 \geq 0$

Production problem

maximize $x_1 + 2x_2$ ← Profits

subject to $x_1 \leq 100$

$2x_2 \leq 200$ ← Resources

$x_1 + x_2 \leq 150$

$x_1, x_2 \geq 0$

Dualize

1. Transform in inequality form

minimize $c^T x$

subject to $Ax \leq b$

$$c = (-1, -2)$$
$$A = \begin{bmatrix} 1 & 0 \\ 0 & 2 \\ 1 & 1 \\ -1 & 0 \\ 0 & -1 \end{bmatrix}$$
$$b = (100, 200, 150, 0, 0)$$

Production problem

maximize $x_1 + 2x_2$ ← Profits

subject to $x_1 \leq 100$

$2x_2 \leq 200$ ← Resources

$x_1 + x_2 \leq 150$

$x_1, x_2 \geq 0$

Dualize

1. Transform in inequality form

minimize $c^T x$

subject to $Ax \leq b$

2. Derive dual

maximize $-b^T y$

subject to $A^T y + c = 0$

$y \geq 0$

$$c = (-1, -2)$$
$$A = \begin{bmatrix} 1 & 0 \\ 0 & 2 \\ 1 & 1 \\ -1 & 0 \\ 0 & -1 \end{bmatrix}$$
$$b = (100, 200, 150, 0, 0)$$

Production problem

Dualized

$$\begin{aligned} &\text{maximize} && -b^T y \\ &\text{subject to} && A^T y + c = 0 \\ &&& y \geq 0 \end{aligned}$$

$$c = (-1, -2)$$

$$A = \begin{bmatrix} 1 & 0 \\ 0 & 2 \\ 1 & 1 \\ -1 & 0 \\ 0 & -1 \end{bmatrix}$$

$$b = (100, 200, 150, 0, 0)$$

Production problem

Dualized

$$\begin{aligned} &\text{maximize} && -b^T y \\ &\text{subject to} && A^T y + c = 0 \\ &&& y \geq 0 \end{aligned}$$

$$c = (-1, -2)$$

$$A = \begin{bmatrix} 1 & 0 \\ 0 & 2 \\ 1 & 1 \\ -1 & 0 \\ 0 & -1 \end{bmatrix}$$

$$b = (100, 200, 150, 0, 0)$$

Fill-in data

$$\text{minimize} \quad 100y_1 + 200y_2 + 150y_3$$

$$\text{subject to} \quad y_1 + y_3 - y_4 = 1$$

$$2y_2 + y_3 - y_5 = 2$$

$$y_1, y_2, y_3, y_4, y_5 \geq 0$$

Production problem

Dualized

$$\begin{aligned} & \text{maximize} && -b^T y \\ & \text{subject to} && A^T y + c = 0 \\ & && y \geq 0 \end{aligned}$$

$$c = (-1, -2)$$

$$A = \begin{bmatrix} 1 & 0 \\ 0 & 2 \\ 1 & 1 \\ -1 & 0 \\ 0 & -1 \end{bmatrix}$$

$$b = (100, 200, 150, 0, 0)$$

Fill-in data

$$\begin{aligned} & \text{minimize} && 100y_1 + 200y_2 + 150y_3 \\ & \text{subject to} && y_1 + y_3 - \cancel{y_4} = 1 \\ & && 2y_2 + y_3 - \cancel{y_5} = 2 \\ & && y_1, y_2, y_3, y_4, y_5 \geq 0 \end{aligned}$$



Eliminate variables

$$\begin{aligned} & \text{minimize} && 100y_1 + 200y_2 + 150y_3 \\ & \text{subject to} && y_1 + y_3 \geq 1 \\ & && 2y_2 + y_3 \geq 2 \\ & && y_1, y_2, y_3 \geq 0 \end{aligned}$$

Production problem

The dual

$$\text{minimize } 100y_1 + 200y_2 + 150y_3$$

$$\text{subject to } y_1 + y_3 \geq 1$$

$$2y_2 + y_3 \geq 2$$

$$y_1, y_2, y_3 \geq 0$$

Production problem

The dual

$$\text{minimize } 100y_1 + 200y_2 + 150y_3$$

$$\text{subject to } y_1 + y_3 \geq 1$$

$$2y_2 + y_3 \geq 2$$

$$y_1, y_2, y_3 \geq 0$$

Interpretation

- **Sell all your resources** at a fair (minimum) price
- Selling must be **more convenient than producing**:
 - Product 1 (price 1, needs 1× resource 1 and 3): $y_1 + y_3 \geq 1$
 - Product 2 (price 2, needs 2× resource 2 and 1× resource 3): $2y_2 + y_3 \geq 2$

Linear optimization duality

Today, we learned to:

- **Dualize** linear optimization problems
- **Prove** weak and strong duality conditions
- **Interpret** simple dual optimization problems

References

- Bertsimas and Tsitsiklis: Introduction to Linear Optimization
 - Chapter 4: Duality theory
- R. Vanderbei: Linear Programming — Foundations and Extensions
 - Chapter 5: Duality theory

Next lecture

More on duality:

- Game theory
- Complementary slackness
- Farkas lemma